



FJD AT1

AUTOSTEERING KIT



HANDS-FREE & MORE PRODUCTIVE

FJD Autosteering Kit uses GNSS and RTK to navigate tractors along straight lines, curves, or concentric circles with sub-inch (2.5cm) accuracy. It works with a wide array of tractors, harvesters, and other agricultural machines.



Guidance Line Management



Farm Management



Terrain Compensation

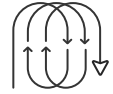

Smart U-turn
*Paid function



*ISOBUS



GIS Information Transfer



One-man Installation

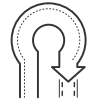

Basic U-turn
*Paid function

*Please contact your sales manager for the brands and models of implements it's compatible with.

GUIDANCE LINE

Straight line, curve, A+ line, and pivot modes are available for diverse field shapes and operation needs.



TERRAIN COMPENSATION

The IMU sensor enables terrain compensation so lines on sloped fields are as straight as those on the even ground.



FIELD MANAGEMENT

Create field profiles to record boundaries, guidance lines, tasks, and more.

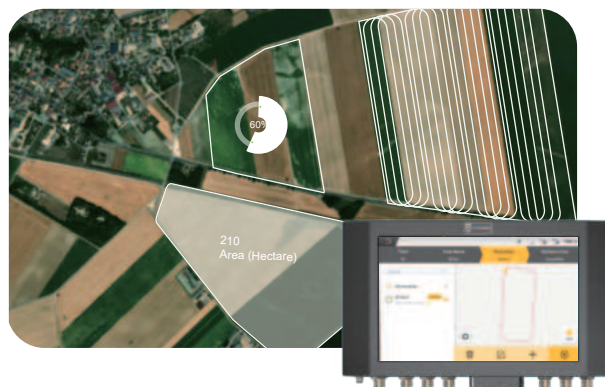

GIS INFO IMPORT&EXPORT

Formats supported: .SHP (SHX/DBF/SHP) and .ISOXML.

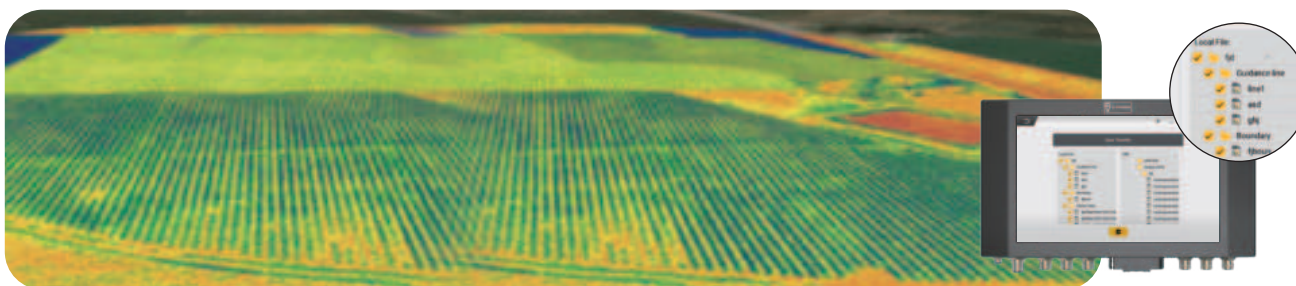

U-TURN

Smart U-turn

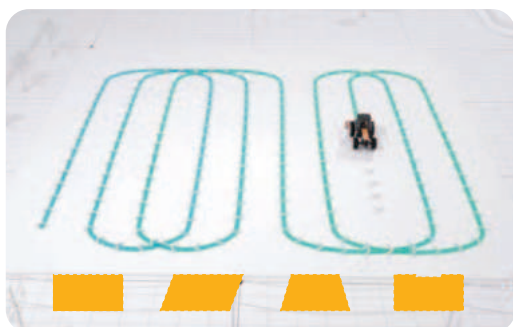

Analyzes the field shape and skips previously worked areas to plan the most suitable path. Turns around automatically and closes the headlands for a seamless operation.

Basic U-turn

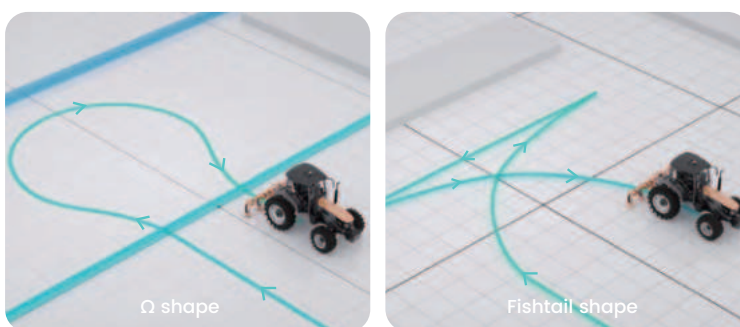

Better suited for irregular fields with ample turning space at the headlands.

Better suited for irregular fields with limited turning space at the headlands.

QUICK SPECS



Control Terminal

Size	300 × 190 × 43 mm
Power Supply	10 V-30 V
Network Module	4G, compatible with 2G / 3G
IP Rating	IP65



Electric Steering Wheel

Size	370 × 370 × 123 mm
Power Input	12 V/24 V
Max Torque	30 N·m



GNSS Antenna

Size	152 × 63 mm
Frequency	GPS:L1, L2; GLONASS: G1, G2; BDS-2: B1I, B3I BDS-3: B1I, B3I, B1C, B2b Galileo: E1, E5b; SBAS: L1; QZSS:L1L2
IP Rating	IP 66

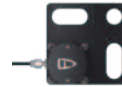

Angle sensor

IP Rating	IP67
Operating Temperature	-40°C - +85°C



IMU

Acceleration Accuracy	0.5 mg
Gyroscope Accuracy	0.1 °/s
Roll and Pitch Angle	0.2°
Power Input	5 V

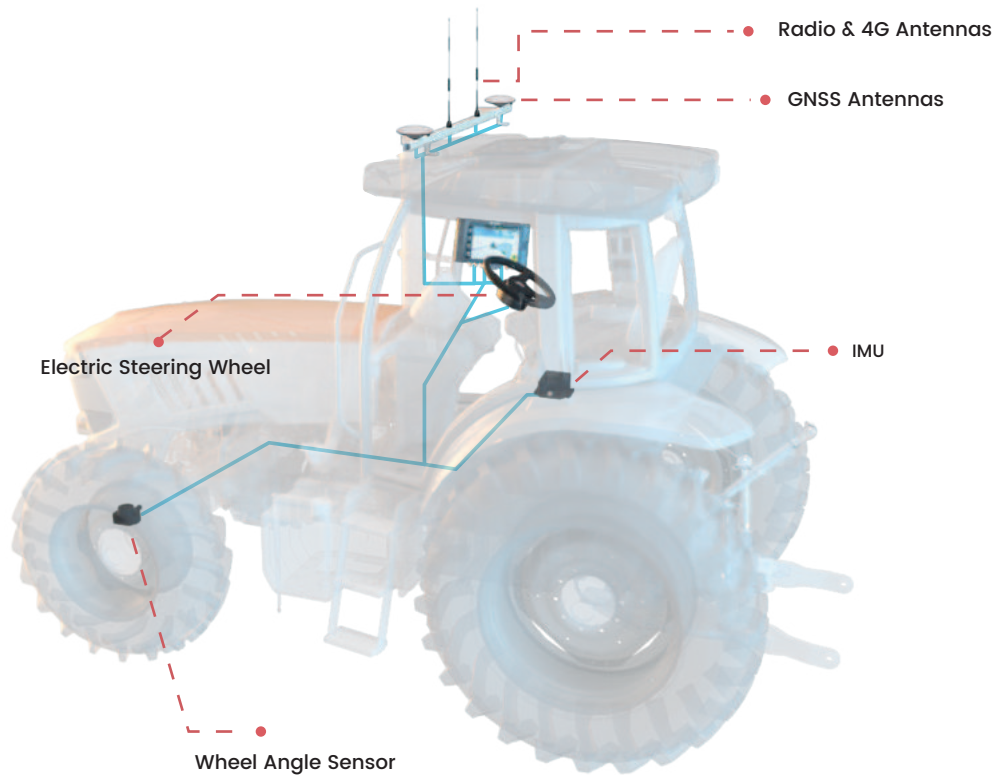

Free Quote: sales.global@fjdynamics.com
Address: 15 SCOTTS ROAD #03-12, Singapore

FJDynamics.com



CREATE FOR A BETTER WORLD

Copyright © 2022 FJDynamics. All rights reserved.